

Fully welded ball valve

Fig.180

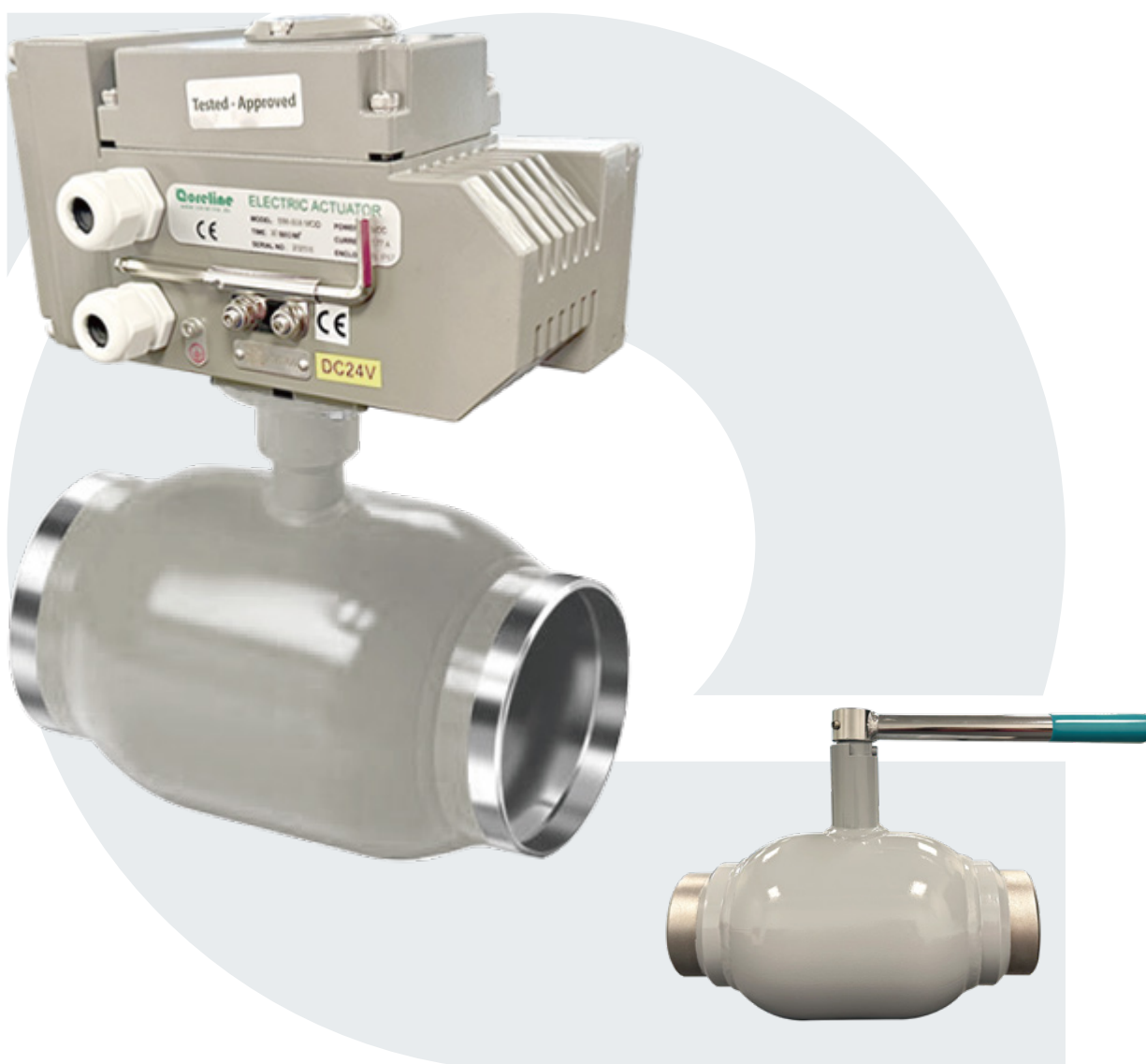

www.coreline.dk

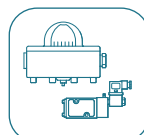
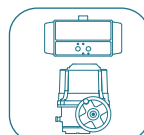
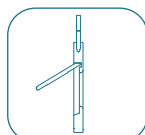
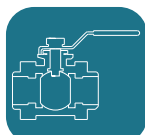
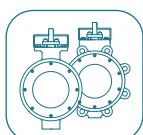
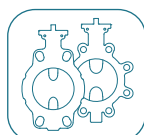

General specification

General description

The fully welded ball valve is engineered for reliable and maintenance-free isolation in heating, cooling, gas, and industrial pipeline systems. The valve body is constructed through full welding, removing flange joints and eliminating external leakage risks.

Both full-bore and reduced-bore are available to meet flow and pressure requirements.

The valve can be supplied with hand lever or with ISO5211 mounting platform for gearbox, electric or pneumatic actuation.

Applications

- District heating and cooling networks
- Gas distribution and energy pipelines
- Water supply and general industrial service
- HVAC systems and building utilities
- Oil and low-viscosity hydrocarbon fluids
- Manual or automated shut-off applications



Specifications

Size range:	DN15-DN400
Bore:	Full bore, reduced bore
Pressure rating:	DN15-DN100: 40bar DN125-DN400: 25bar
Temperature range:	-20~+200 °C (Not applicable for steam)
Body material:	Carbon steel
Ball:	Stainless steel 304
Stem:	Stainless steel 420
Seats:	PTFE + 20% carbon
End connections:	Butt weld, Threaded BSPP, Flanged
Operation	Manual or ISO5211 mounting platform
Leakage rate:	ISO 5208 Rate A / EN 12266-1 Rate A (bubble-tight)

Design features

Features

- Fully welded body construction minimizes leakage risk, and ensures long-term structural integrity.
- Compact and lightweight design facilitates installation and reduces overall system load.
- Reinforced PTFE + 20% carbon seats are very suitable for high pressure and temperature. Furthermore they are good for wear, so you will achieve a long cycle life.
- Precision-machined, mirror-polished ball ensures bubble-tight shutoff with consistently low operating torque.
- Ball with an integrated cylindrical flow channel ensures a straight, parallel flow path through the valve, minimizing turbulence and pressure loss.
- Optional customized ISO5211 mounting pad allows direct actuator installation without brackets.
- Extended stem type is available for isolation purposes.

Sealing design:Reduced bore

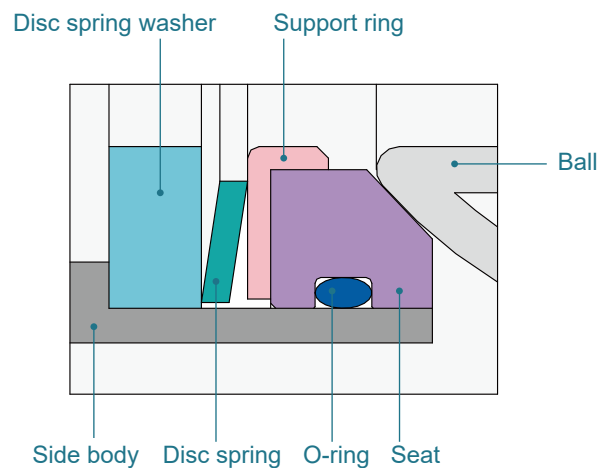

Sealing design:Full bore

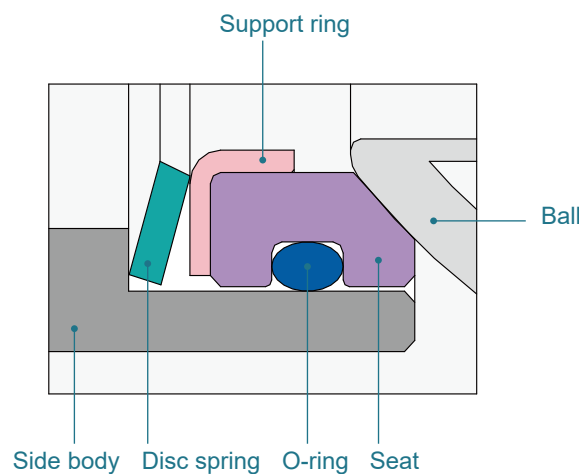

Material part list

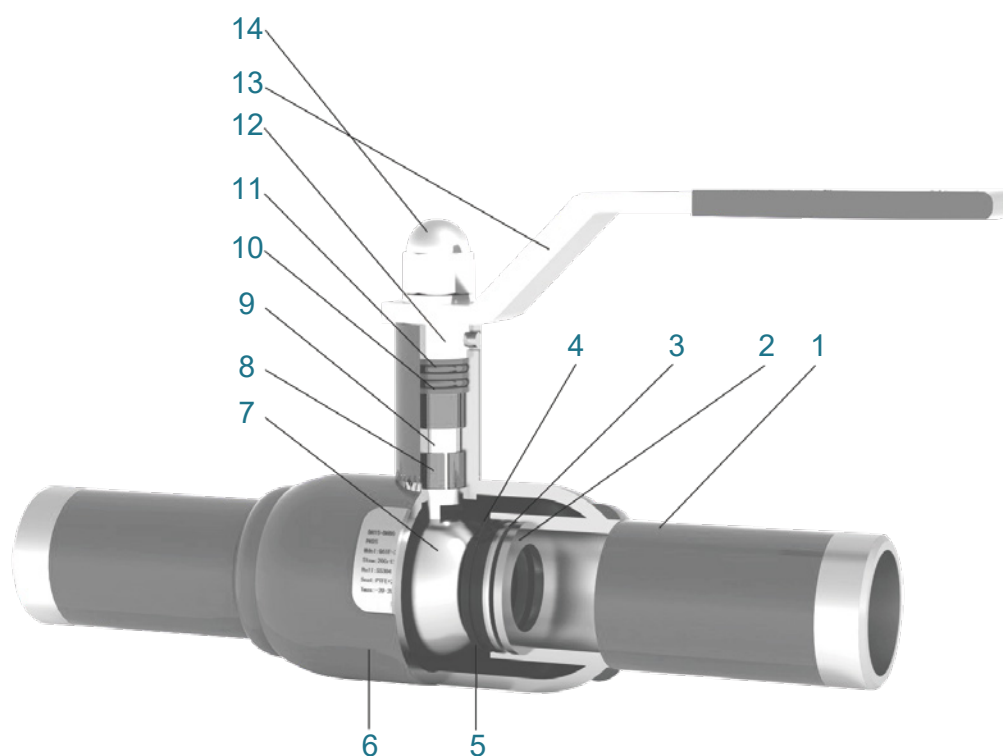

Item	Part name	Material
1	Side tube	20# steel
2	¹⁾ Spring washer	SS304
3	Spring	65Mn
4	Seat washer	SS304
5	Seat	PTFE + 20% carbon
6	Body	20# steel
7	Ball	SS304
8	Bushing	PTFE+Cu
9	Stem	SS420
10	Packing washer	RPTFE
11	O-ring	VITON-B
12	Packing gland	SS304
13	Handle	20#+Zn
14	Lock cap	SS304

1) Spring washer is only for reduce bore type.

Dimensions - Reduce bore

Reduce bore DN15 - DN200

15R - 50R

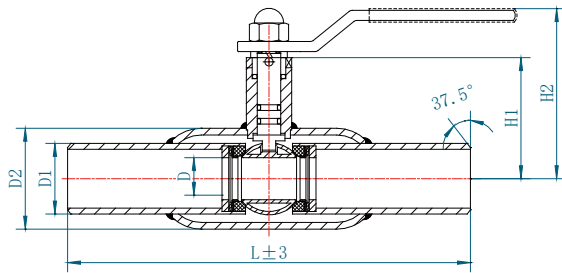

65R - 200R

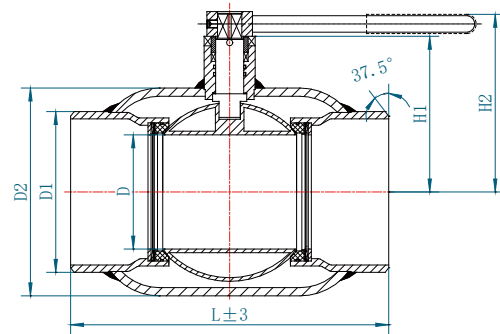

DN	INCH	RATING	L	D	D1	D2	H1	H2
15	1/2"	40bar	210	10	21.2	34	60	94
20	3/4"	40bar	230	15	27	42	63	97
25	1"	40bar	230	20	34	52	68.5	102.5
32	1 1/4"	40bar	260	25	42	60	74.5	111
40	1 1/2"	40bar	260	32	48	76	93.5	133.5
50	2"	40bar	300	40	57	89	100	142.6
65	2 1/2"	40bar	300	50	76	108	123	147
80	3"	40bar	300	65	89	133	139	163
100	4"	40bar	325	80	108	159	160	187
125	5"	25bar	325	100	133	180	186	216.3
150	6"	25bar	350	125	159	219	210.5	243.5
200	8"	25bar	400	150	219	273	236.5	264.5

Reduce bore DN125 - DN350

* Prepared for direct installation of actuators

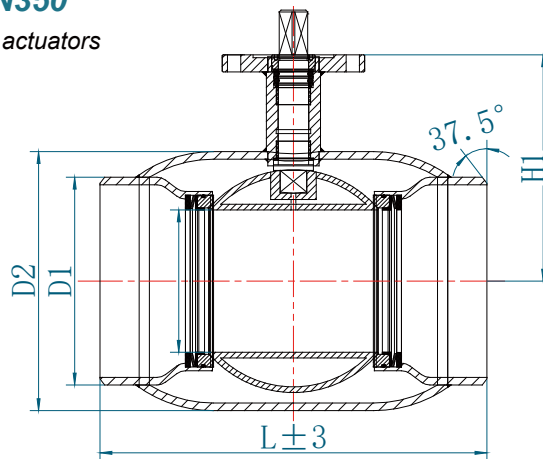

DN	INCH	RATING	L	D	D1	D2	H1	ISO5211	Stem Square - H
125	5"	25bar	325	100	133	159	187	F07+F10	17×17 - 18mm
150	6"	25bar	350	125	159	219	210	F07+F10	22×22 - 24mm
200	8"	25bar	400	150	219	273	238.5	F10+F12	22×22 - 24mm
250	10"	25bar	560	200	273	351	288.5	F14+F16	27×27 - 30mm
300	12"	25bar	620	250	325	426	328	F16	36×36 - 39mm
350	14"	25bar	686	300	377	508	385.5	F16+F25	46×46 - 49mm

Dimensions - Full bore

Full bore DN15 - DN200

15F - 50F

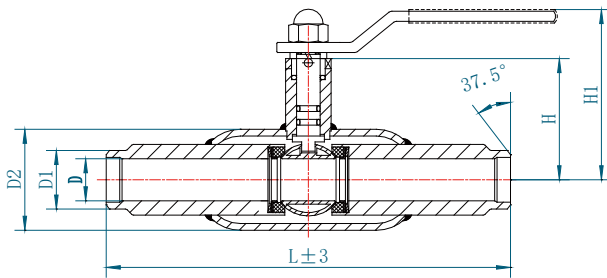

65F - 150F

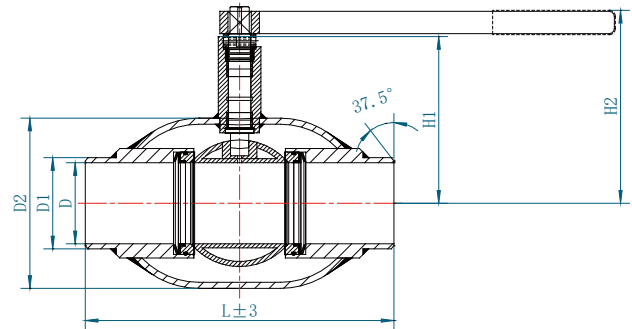

DN	INCH	RATING	L	D	D1	D2	H1	H2
15	1/2"	40bar	230	15	21.2	42	63	97
20	3/4"	40bar	230	20	27	52	69	105.5
25	1"	40bar	260	25	34	60	74.5	111
32	1 1/4"	40bar	260	32	42	76	93.5	133.5
40	1 1/2"	40bar	300	40	48	89	100	142.5
50	2"	40bar	300	50	60	108	123	181
65	2 1/2"	40bar	300	65	76	133	135.5	159.5
80	3"	40bar	325	80	90	168	164.5	191.5
100	4"	40bar	350	100	114	180	186	216
125	5"	25bar	390	125	137	219	210.5	243.5
150	6"	25bar	520	150	165	273	236.5	264.5

Full Bore DN125 - DN400

* Prepared for direct installation of actuators

125F - 250F

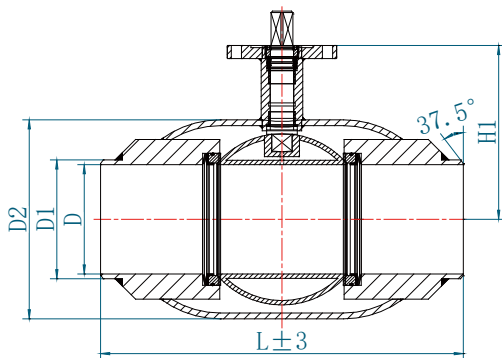

300F - 400F

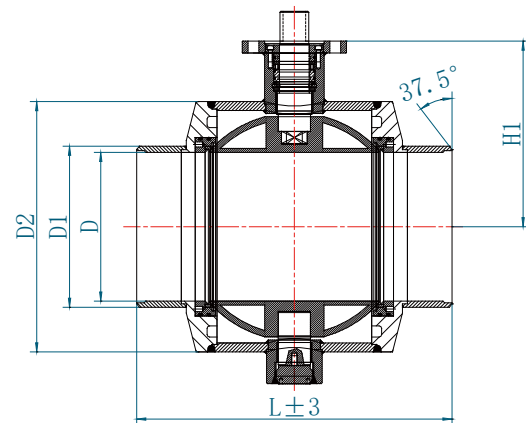

DN	INCH	RATING	L	D	D1	D2	H1	ISO5211	Stem Square - H
125	5"	25bar	390	125	137	219	210	F07+F10	22×22 - 24mm
150	6"	25bar	520	150	165	273	238.5	F10+F12	22×22 - 24mm
200	8"	25bar	635	200	219	351	288.5	F14+F16	27×27 - 30mm
250	10"	25bar	689	250	273	426	328	F16	36×36 - 39mm
300	12"	25bar	635	300	325	505	374.5	F16+F25	46×46 - 49mm
350	14"	25bar	762	334	377	560	409	F25	46×46 - 49mm
400	16"	25bar	838	387	426	653	455	F25	φ75 - 90mm

Dimensions BSPP×Weld, options

Full bore - BSPP×Weld ends

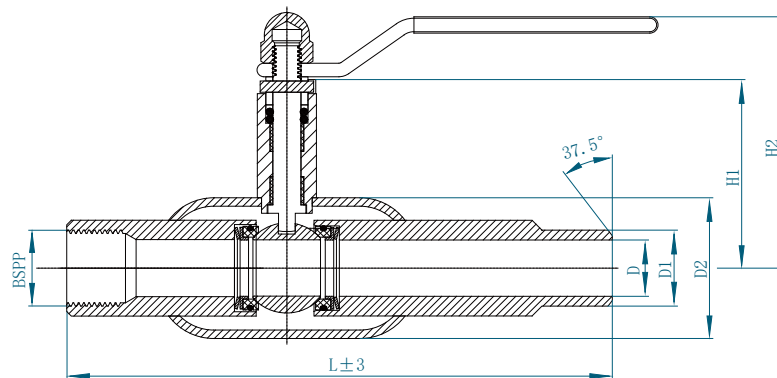

DN	INCH	RATING	L	D	D1	D2	H1	H2
15F	1/2"F	40bar	197	15	21.2	42	63	85
20F	3/4"F	40bar	197	20	27	50	67	89
25F	1"F	40bar	229	25	34	60	74.5	102

Customized solutions & options



* Contact Coreline for detailed specifications.

Technical specifications

Technical data

DN	INCH	Full bore			Reduced bore	
		¹⁾ Kv	²⁾ Torque [Nm]	³⁾ Weight [kg]	Kv	²⁾ Torque [Nm]
15	1/2"	24	5	0.7	9	5
20	3/4"	49	7	1.5	15	5
25	1"	78	15	2.3	28	7
32	1 1/4"	115	20	2.8	44	15
40	1 1/2"	207	25	4.6	77	20
50	2"	312	35	7.1	118	25
65	2 1/2"	518	65	8.9	196	35
80	3"	834	89	12.7	293	65
100	4"	1265	110	19	481	89
125	5"	2088	140	25	772	110
150	6"	3617	283	72	1215	140
200	8"	6780	680	128	1723	283
250	10"	14115	1310	190	3106	680
300	12"	21227	1910	265	5218	1310
350	14"	26670	4200	-	7553	1910
400	16"	36935	5700	-	10700	4200

Notes

1) The flow coefficient (Kv) is defined as the volume flow rate of water in m³/h through a fully open valve with $\Delta P = 1$ bar. The conversion between Kv and Cv can be calculated as:

$$Cv \approx 1.156 \times Kv \quad \text{or} \quad Kv \approx 0.865 \times Cv$$

2) The torque values are based on a working pressure of 25 bar and do not include a safety factor. For standard applications, we recommend applying a safety factor of 1.3 when sizing the actuator. For special applications, please contact Coreline.

3) Weights for DN15–DN150 include handle; larger sizes are with ISO5211 mounting flange and bare stem. Weights of additional sizes will be updated as applicable.

Pressure temperature curve (PTFE+25% carbon)

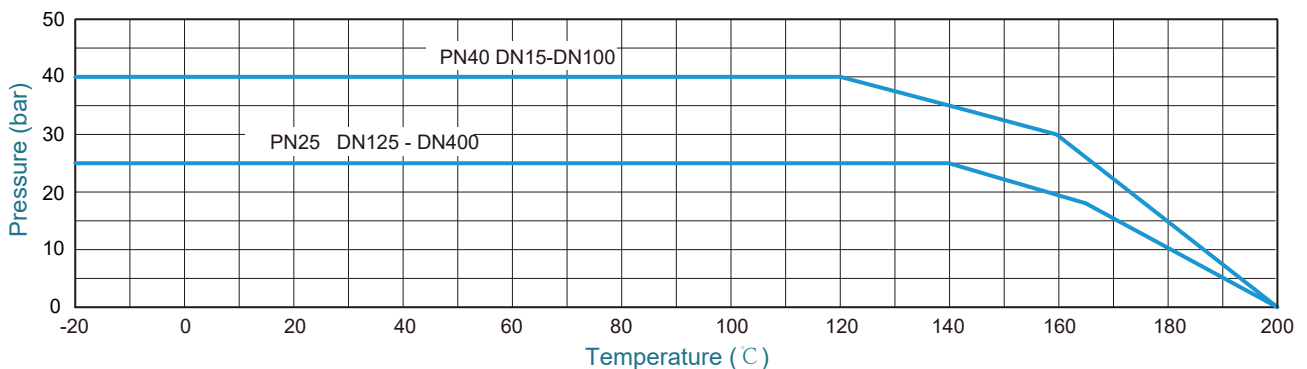

OBS: Working temperature range -20°C ~ +200°C (Not applicable for steam).

Coreline

The contents of this catalogue are confidential and proprietary to Coreline, we reserve the right to change the specifications without any notice.

CORELINE LTD.

Add: No.4 Wangjiang Road, Muqiao Town, Zhengpugang New District, 238200 Hexian, Ma'anshan City, Anhui Province, China

Http: // www.coreline.dk

E-mail : mail@coreline.cn